

CRIMPING TOOL

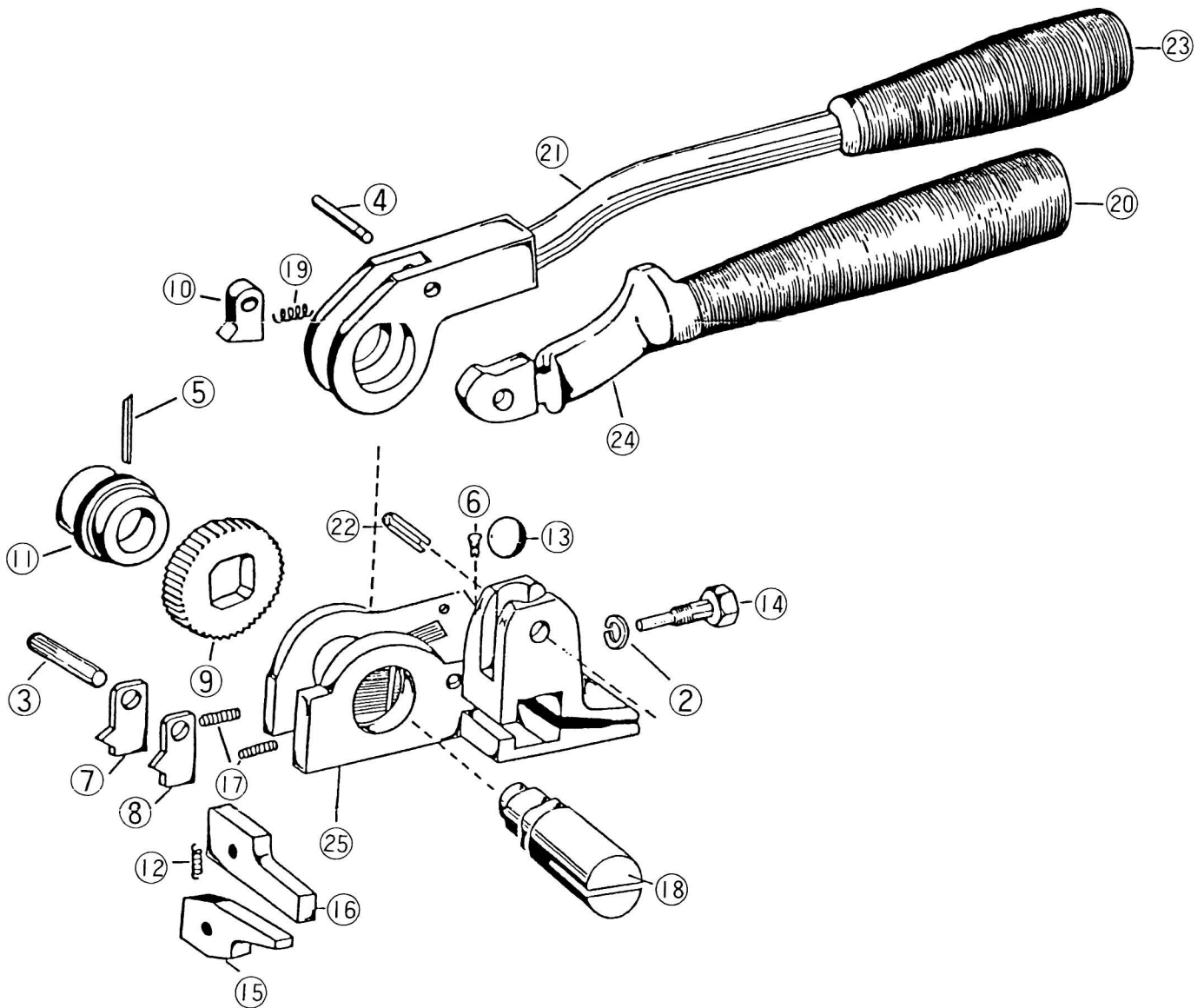

PART NO.	PART NAME	QTY/TOOL	PART NO.	PART NAME	QTY/TOOL
2	Washer	1	14	Shear Blade Screw	1
3	Pawl Pin	1	15	Shear Balde A	1
4	Lever Pin	1	16	Shear Balde B	1
5	Pin	1	17	Pawl Spring	2
6	Screw	1	18	Windlass Shaft	1
7	Pawl Stop A	1	19	Spring	1
8	Pawl Stop B	1	20	Handle A	1
9	Ratchet Wheel	1	21	Lever A	1
10	Drive Pawl	1	22	Roll Pin	1
11	Hammer Knob	1	23	Handle B	1
12	Shear Blade Spring	1	24	Lever B	1
13	Detent Ball	1	25	Body	1

This Tensioning / Crimping Tool will tension, cut and crimp steel strapping when used with "Wing Seal" type clips. Please follow all instructions for best results.

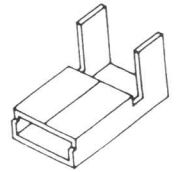

OPERATING HINT: Lengths of strap can be handled safely, easily and economically by placing the reel or box *underneath* or *at the side* of the shipping bench.

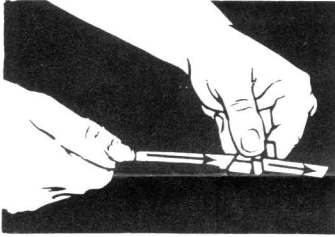

1. Slide the strap through the seal. Note position of seal, with lugs held up and away from the operator.

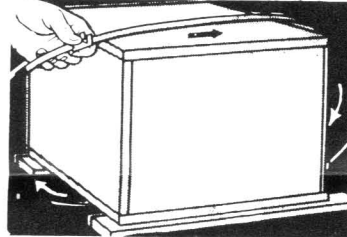

2. Pull the strap THROUGH THE SEAL over top of box, down side, and back underneath.

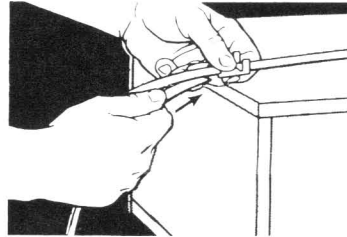

3. Thread the strap through the seal the second time, completing the loop. About a four-inch length of strap should protrude through the seal.

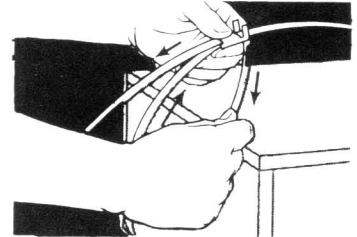

4. Bend back the under layer of strapping as shown to form a flap between the seal and the box.

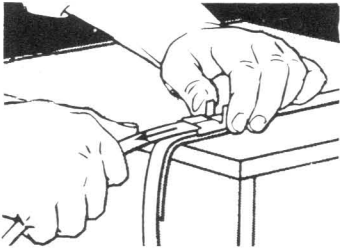

5. Pull strap tightly around box and through seal. Note 1-inch distance between seal and box edge, also correct position of underflap.

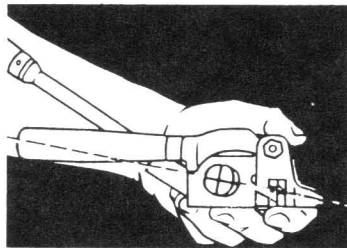

6. Hold tool in left hand as shown. Line up slots in the nose and ratchet so they are on a straight line, as indicated by the dashed line.

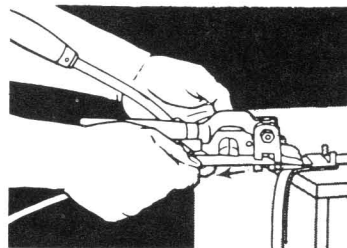

7. Insert the strap through nose and ratchet slots.

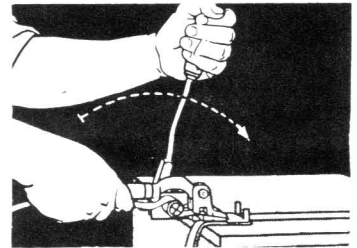

8. Hold short handle in right hand in position shown. Push long handle forward in full arc with left hand. This tightens the strap.

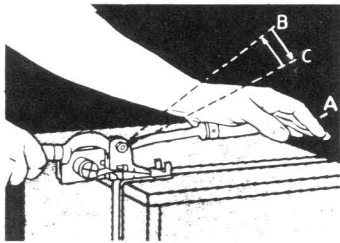

9. If strap needs further tightening, pull long handle back from position "A" to position "B". Tighten strap with short easy strokes from "B" to "C".

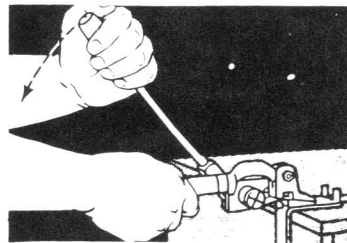

10. Bring long handle back to original starting position as in Figure 7.

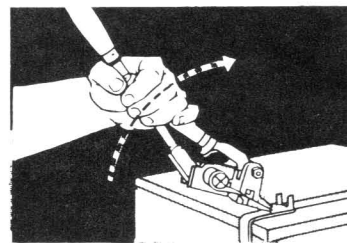

11. Take both handles in left hand and move both forward as shown.

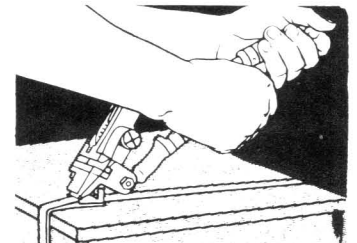

12. Hold long handle in left hand. Grasp short handle in right hand.

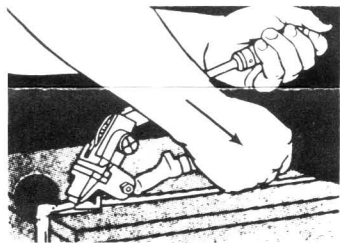

13. Push small handle downward with right hand. This cuts the strap.

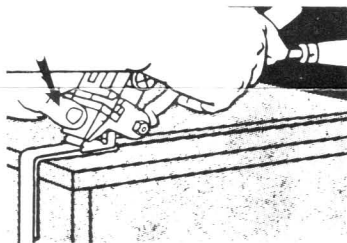

14. Hold both handles in right hand. Place thumb of left hand against base of the Tool ready to press down against severed strap.

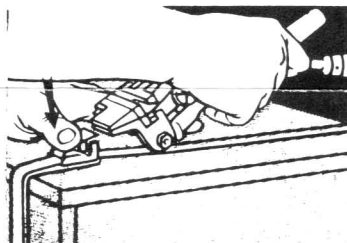

15. Move Tool forward and away from the seal. Press the severed strap end downward between the lugs with your thumb.

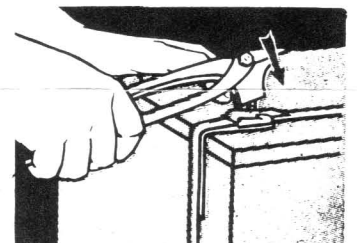

16. Hammer down the lugs with the knob on the left side of the tool to complete the tie.